



Designation: D1932 – 19

# Standard Test Method for Thermal Endurance of Flexible Electrical Insulating Varnishes<sup>1</sup>

This standard is issued under the fixed designation D1932; the number immediately following the designation indicates the year of original adoption or, in the case of revision, the year of last revision. A number in parentheses indicates the year of last reappraisal. A superscript epsilon ( $\epsilon$ ) indicates an editorial change since the last revision or reappraisal.

*This standard has been approved for use by agencies of the U.S. Department of Defense.*

## 1. Scope\*

1.1 This test method covers the determination of the relative thermal endurance of flexible electrical insulating varnishes by determining the time necessary at elevated temperatures to decrease the dielectric breakdown of the varnish to an arbitrarily selected value when applied to a standard glass fiber fabric.

1.2 This test method does not apply to varnishes that lose a high percentage of their dielectric breakdown voltage when flexed before elevated temperature exposure as prescribed in the screening test (Section 9). Examples of such varnishes are those used for high speed armatures and laminated structures. Also, this test method is not applicable to varnishes which distort sufficiently during thermal elevated temperature exposure so that they cannot be tested using the curved electrode assembly.

1.3 Thermal endurance is expressed in terms of a temperature index.

1.4 The values stated in SI units are to be regarded as standard. No other units of measurement are included in this standard.

NOTE 1—There is no equivalent IEC or ISO standard.

1.5 *This standard does not purport to address all of the safety concerns, if any, associated with its use. It is the responsibility of the user of this standard to establish appropriate safety, health, and environmental practices and determine the applicability of regulatory limitations prior to use.* For specific hazard statements, see Section 7.

1.6 *This international standard was developed in accordance with internationally recognized principles on standardization established in the Decision on Principles for the Development of International Standards, Guides and Recom-*

<sup>1</sup> This test method is under the jurisdiction of ASTM Committee D09 on Electrical and Electronic Insulating Materials and is the direct responsibility of Subcommittee D09.01 on Electrical Insulating Products.

Current edition approved Nov. 1, 2019. Published November 2019. Originally approved in 1967. Last previous edition approved in 2018 as D1932 – 18. DOI: 10.1520/D1932-19.

*mendations issued by the World Trade Organization Technical Barriers to Trade (TBT) Committee.*

## 2. Referenced Documents

### 2.1 ASTM Standards:<sup>2</sup>

D149 Test Method for Dielectric Breakdown Voltage and Dielectric Strength of Solid Electrical Insulating Materials at Commercial Power Frequencies

D374/D374M Test Methods for Thickness of Solid Electrical Insulation

D580/D580M Specification for Greige Woven Glass Tapes and Webbing

D618 Practice for Conditioning Plastics for Testing

D1346 Test Method for Testing Electrical Insulating Varnishes for 180 C and Above (Withdrawn 1986)<sup>3</sup>

D1711 Terminology Relating to Electrical Insulation

D2307 Test Method for Thermal Endurance of Film-Insulated Round Magnet Wire

D2518 Specification for Woven Glass Fabrics for Electrical Insulation (Withdrawn 2013)<sup>3</sup>

D5423 Specification for Forced-Convection Laboratory Ovens for Evaluation of Electrical Insulation

### 2.2 IEC Publications:

IEC 60216 Guide for the Determination of Thermal Endurance Properties of Electrical Insulating Materials (Part 1)<sup>4</sup>

## 3. Terminology

### 3.1 Definitions:

3.1.1 For definitions of terms used in this test method refer to Terminology D1711.

### 3.2 Definitions of Terms Specific to This Standard:

3.2.1 *temperature index (TI), n*—a number which permits comparison of the temperature/time characteristics of an electrical insulating material, or a simple combination of materials,

<sup>2</sup> For referenced ASTM standards, visit the ASTM website, [www.astm.org](http://www.astm.org), or contact ASTM Customer Service at [service@astm.org](mailto:service@astm.org). For Annual Book of ASTM Standards volume information, refer to the standard's Document Summary page on the ASTM website.

<sup>3</sup> The last approved version of this historical standard is referenced on [www.astm.org](http://www.astm.org).

<sup>4</sup> Available from American National Standards Institute, 25 West 43rd St., 4th Floor, New York, NY 10036.

\*A Summary of Changes section appears at the end of this standard

based on the temperature in degrees Celsius which is obtained by extrapolating the Arrhenius plot of endpoint time versus temperature to a specified time, usually 20 000 h.

3.2.2 *thermal endurance graph, n*—an Arrhenius plot.

3.2.3 *thermal endpoint time, n*—the time necessary for a specific property of a material, or a simple combination of materials, to degrade to a defined end point when aged at a specified temperature.

3.2.4 *thermal life endpoint time, n*—a graphical representation of thermal endpoint time at a specified exposure temperature in which the value of a property of a material, or a simple combination of materials, is measured at room temperature and the values plotted as a function of time.

3.2.5 *varnish, electrical insulating, n*—a liquid resin system that is applied to and cured on electrical components providing electrical, mechanical, and environmental protection.

3.2.5.1 *Discussion*—There are two types of electrical insulating varnish: solvent-containing and solventless. The solvent-containing varnish is a solution, dispersion, or emulsion of a polymer or mixture of polymers in a volatile, nonreactable liquid. The solventless type is a liquid resin system free of volatile, nonreactable solvents.

#### 4. Summary of Test Method

4.1 Specimens are prepared using glass cloth coated with the selected varnish to a specified build.

4.2 Specimens are exposed in air at a minimum of three temperatures above the expected use temperature of the material. Dielectric breakdown voltage tests in air at room temperature are periodically made to determine the exposure time at each test temperature required to reduce the breakdown voltage to a value of 12 kV/mm (300 V/mil) of original thickness.

These values are used to construct a thermal endurance graph for use to estimate temperature indices.

4.3 This test method is not applicable to materials having an initial dielectric breakdown voltage of less than 12 kV/mm (300 V/mil) of original thickness unless lower endpoint values are agreed upon or indicated in the applicable material specifications.

#### 5. Significance and Use

5.1 A major factor affecting the long term performance of insulating materials is thermal degradation. It is possible that factors, such as moisture and vibration, will cause failures after the material has been weakened by thermal degradation.

5.2 An electrical insulating varnish is effective in protecting electrical equipment only as long as it retains its physical and electrical integrity.

5.3 The thermal degradation of the varnish results in weight loss, porosity, crazing, and generally a reduction in flexibility. Degradation of the varnish can be detected by a decrease in dielectric strength, which is therefore used as the failure criterion for this test method.

5.4 Electrical insulating varnishes undergo flexing in service due to vibration and thermal expansion. For this reason, this functional test includes flexing and elongation of the insulation. The electrodes used in this test method are designed to elongate the outer surface of the specimen 2 % with respect to the neutral axis of the base fiber while being tested for dielectric breakdown.

#### 6. Apparatus

6.1 *Electrode Test Fixture*—The fixture shall be in accordance with the dimensions shown in Fig. 1 and Fig. 2.

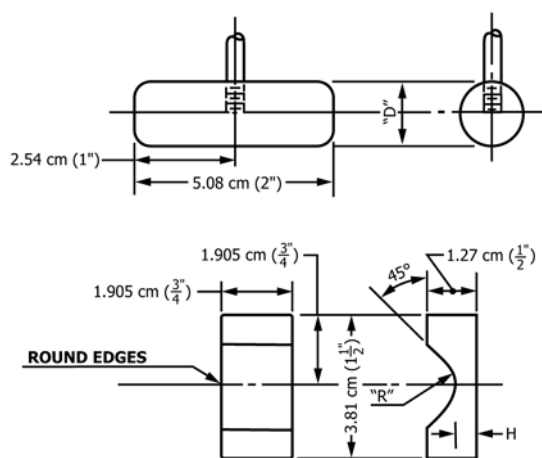

Insulation Thickness		Dimension R		Dimension H		Dimension D	
cm	in.	cm	in.	cm	in.	cm	in.
0.018	0.007	0.455	0.179	0.815	0.321	0.871	0.344

Tolerance for R and D = 0.003 cm (0.001 in.)  
Tolerance for H = 0.005 cm (0.002 in.)

FIG. 1 Single-Shot Curved Electrode Details